

REVISIONS					
ECN	REV	DESCRIPTION	ZONE	BY	DATE
27701	A	NEW RELEASE		JDS	12/2/2022
H 30382	B	UPDATE 1027173, UPDATE COMPONENTS, ADD ADAPTERS	F5, G1, G2, G5	JDS	4/4/2024
32169	C	REPLACE (2) FS6400-16-16-O WITH (2) 4604-16-16-ORB, UPDATE FUEL PICK UP ORIENTATION	C7, F2, G7	JDO	4/14/2025

ITEM NO.	PART NUMBER	QTY	DESCRIPTION
1	1027173	1	WELDMENT, FUEL TANK, 8680
2	1011971	1	PLUG, MAGNETIC DRAIN, -16 SAE ORB
3	1014538-17.75	2	TUBE, FUEL, PICK UP, 17.75"
4	1027180	1	SENSOR, FUEL, 8680
5	1024829	1	ASSEMBLY, ANGLED FILLER CAP
6	1027371	1	PLATE, BRACE, RADIATOR DUCT TO FUEL TANK
7	5LOC-4RMP	2	FITTING, PUSH LOK, -5LOC/-4RMP
C 8	4604-16-16-ORB	2	FITTING, STRAIGHT, -16HB / -16 O-RING
9	122-#10-32-8F	5	PHMS, CROSS, #10-32 X 0.5, FT
10	100-4-20-8-5F	7	CSHH, 1/4-20 X 0.5, GR5, FT
11	302-4	7	WASHER, LOCK, 1/4
12	100-6-16-12-5F	2	CSHH, 3/8-16 X 0.75, GR5, FT
13	302-6	2	WASHER, LOCK, 3/8
14	300-6	2	WASHER, FLAT, SAE, 3/8

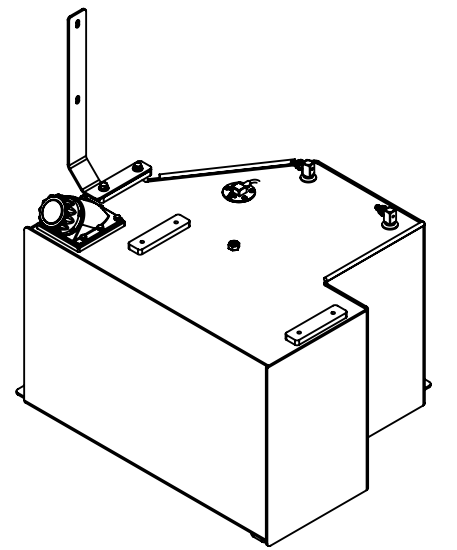
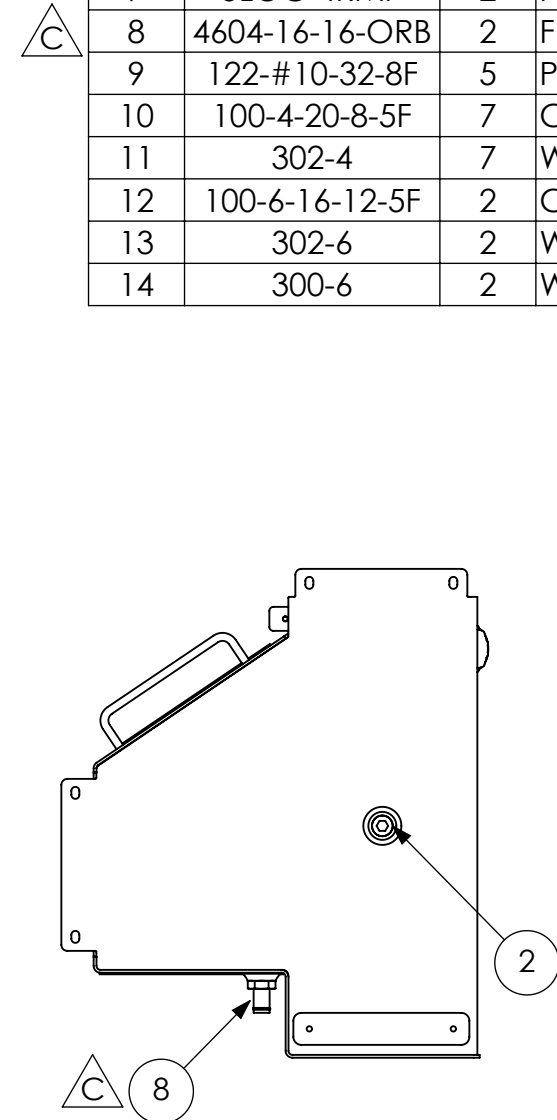
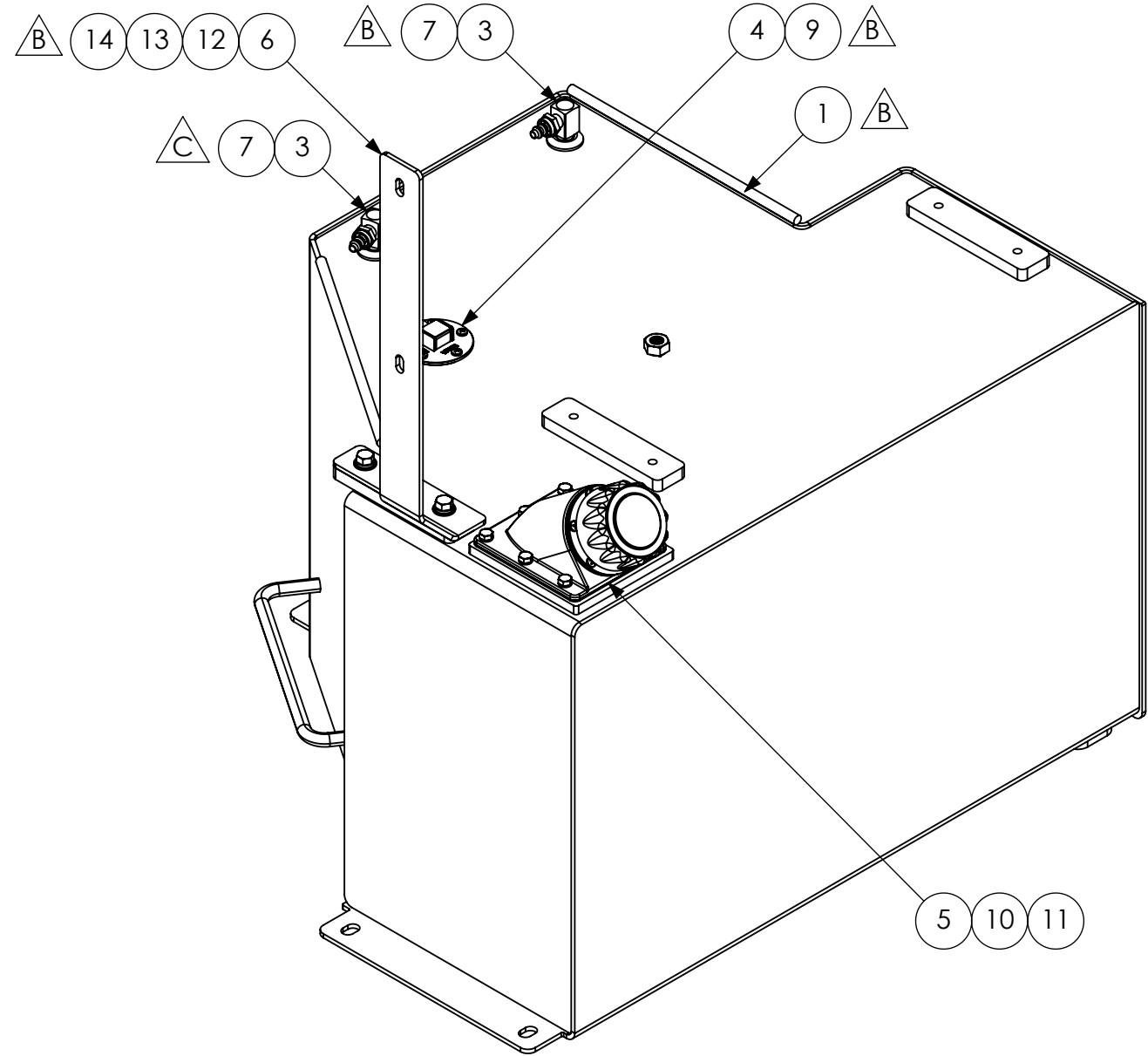

NOTES:  
1.

FINISH PER LEEBOY SPECIFICATION DRAWING 1014877													DIMENSIONS ARE IN INCHES UNLESS OTHERWISE SPECIFIED		APPROVALS		DATE		<b>1027176</b>					
GENERAL FABRICATION TOLERANCE - INCH													DIMENSIONS APPLY TO FINISHED PART. ROUGH CUTS MUST INCLUDE APPROPRIATE STOCK ALLOWANCE FOR MACHINED PARTS.		DRAWN BY TWJ		04/26/2022		ASSEMBLY, FUEL TANK, 8680					
SURFACE: 250													(REFERENCE DIMENSIONS)		CHECKED BY TWJ		04/16/2025							
GENERAL MACHINING TOLERANCE													REFER TO TABLES FOR GENERAL TOLERANCES		INFORMATION CONTAINED ON THIS DRAWING IS THE SOLE PROPERTY OF LEEBOY. ANY REPRODUCTION IN PART OR WHOLE WITHOUT THE WRITTEN PERMISSION OF LEEBOY IS PROHIBITED		THIRD ANGLE PROJECTION		SHT SIZE: B		SHT 1 OF 1		PART WEIGHT: 164.46 LBS	
SURFACE: 125													SHEET SCALE: 1:6											
>	0.000	3.000	12.000	24.000	48.000	96.000	120.000	240.000	0.000	1.000	3.000	6.000	12.000	36.000										
≤	3.000	12.000	24.000	48.000	96.000	120.000	240.000	~	1.000	3.000	6.000	12.000	36.000	~										
±	0.015	0.031	0.063	0.094	0.125	0.188	0.250	0.500	0.005	0.010	0.015	0.031	0.063	0.094										
ANGLE	±0.5°		±1.0°		±2.0°		±3.0°		±0.1°		±0.3°		±0.5°											

**LeeBoy**  
ST ENGINEERING LEEBOY,  
dba LEEBOY  
500 LINCOLN COUNTY  
PARKWAY EXT  
LINCOLNTON, NC 28092